

COMBIVERT

CE

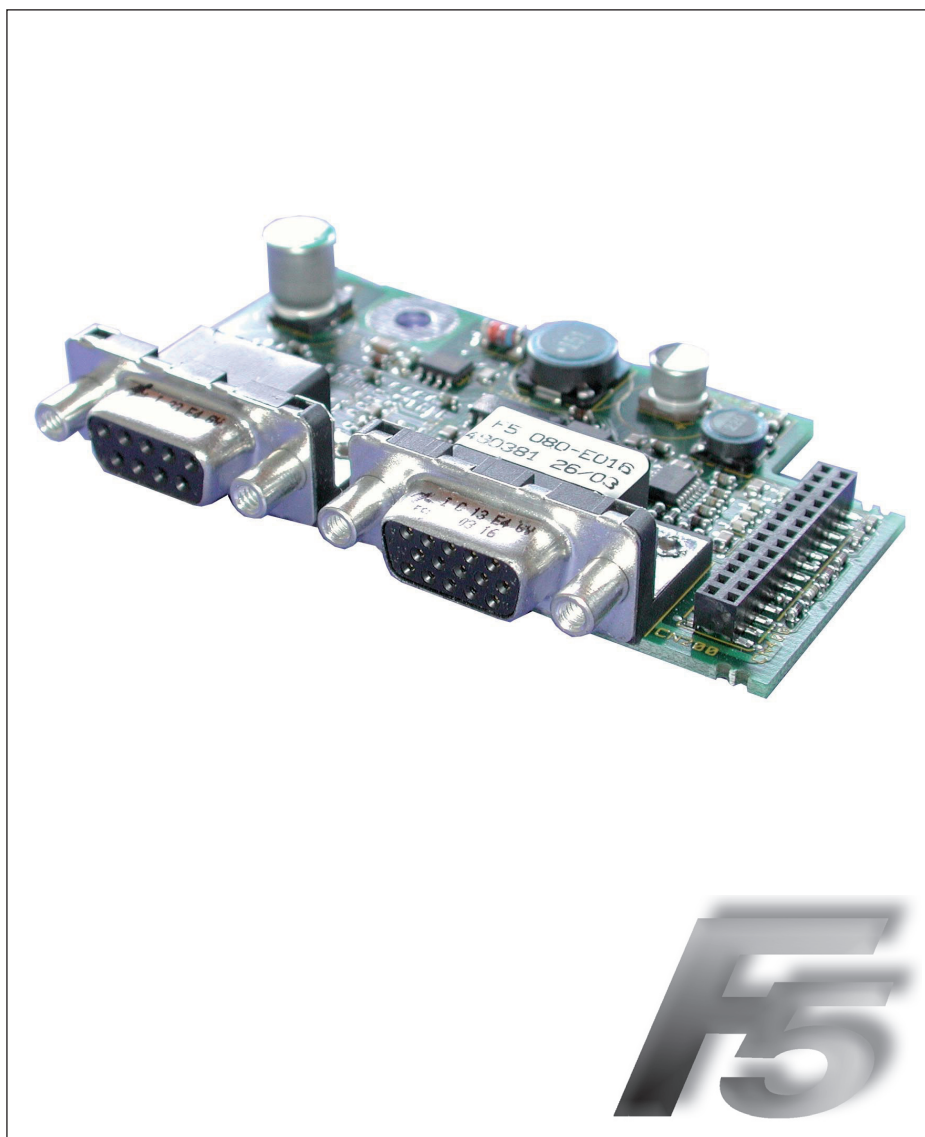

GB INSTRUCTION MANUAL

Channel 1
Channel 2

Encoder Interface

Resolver
variable

Mat.No.	Rev.
DRF5ZEM-K001	1C





1. Safety Instructions	4
1.1 Validity	4
1.2 Qualification.....	4
2. Product Description.....	5
2.1 General.....	5
2.2 Material number	5
2.3 Scope of delivery (option or replacement delivery)	5
2.4 Mechanical installation	6
3. Description of the Interface	6
3.1 Channel 1	6
3.1.1 Specifications	6
3.1.2 Description of the socket X3A	6
3.1.3 Input signals channel 1	7
3.1.3.1 Signal tracks	7
3.1.3.2 Encoder breakage recognition channel 1	7
3.1.4 Connection of the encoder	8
3.1.5 Encoder cable	8
3.1.6 Encoder line length.....	8
3.1.7 Tested encoders	9
3.2 Channel 2	9
4. Start-up	9
4.1 Special resolver.....	10
5. Error Messages.....	10

1. Safety Instructions

Prior to performing any work on the unit the user must familiarize himself with the unit. This includes especially the knowledge and observance of the safety and warning directions. The pictographs used in this Instruction Manual have following meaning:



Danger

Refers to danger of life by electric current.



Warning

Refers to possible danger of injury or life.



Note

Refers to tips and additional information.

1.1 Validity

The information contained in the technical documentation, as well as any user-specific advice in spoken and written and through tests, are made to best of our knowledge and information about the application. However, they are considered for information only without responsibility. This also applies to any violation of industrial property rights of a third-party.

Inspection of our units in view of their suitability for the intended use must be done generally by the user. Inspections are particularly necessary, if changes are executed, which serve for the further development or adaptation of our products to the applications (hardware, software or download lists). Inspections must be repeated completely, even if only parts of hardware, software or download lists are modified.



Controlling by the user

Application and use of our units in the target products is outside of our control and therefore lies exclusively in the area of responsibility of the user.



Use under special conditions

The used semiconductors and components of KEB are developed and dimensioned for the use in industrial products. If the KEB COMBIVERT is used in machines, which work under exceptional conditions or if essential functions, life-supporting measures or an extraordinary safety step must be fulfilled, the necessary reliability and security must be ensured by the machine builder.

1.2 Qualification

All operations serving transport, installation and commissioning as well as maintenance are to be carried out by skilled technical personnel (observe IEC 364 or CENELEC HD 384 or DIN VDE 0100 and national accident prevention rules!). According to this manual qualified staff means those who are able to recognise and judge the possible dangers based on their technical training and experience and those with knowledge of the relevant standards and who are familiar with the field of power transmission (VDE 0100, VDE 0160 (EN 50178), VDE 0113 (EN 60204) as well as the appropriate regulations for your area.



Danger by high voltage

KEB electronics components contain dangerous voltages which can cause death or serious injury. In operation, drive converters, depending on their degree of protection, may have live, uninsulated, and possibly also moving and hot surfaces.

In case of inadmissible removal of the required covers, of improper use, wrong installation or maloperation, there is the danger of serious personal injury and damage to property.

2. Product Description

Figure 1: Resolver at channel 1	
2MF5280-0028 /-0029	1MF5280-0028 /-0029
X3B Channel 2 variable see material number	X3A Channel 1 Resolver

2.1 General

Each of the interface cards delivered by KEB include two interfaces. As there are numerous different combinations available each interface will be described by means of separate instructions. The instruction covers the installation of the interface card, the connection as well as the start-up of a suitable encoder. Further information and the parameter adjustments are described in the application manual for the inverter/servo.

2.2 Material number

xM	F5	K8G	X	X	X	X
			Term of delivery	0 installed	Z	Option, spare part
				5 SSI	0025	
				E TTL-Output	0029	H TTL-Input 0028
				F5 Series		
applicable for housing size				1M D, E (circuit board 1MF5280-xxxx see above)		
				2M G...U (circuit board 2MF5280-xxxx see above)		

2.3 Scope of delivery (option or replacement delivery)

- Encoder interface
- two instruction manuals
- fixing bolt
- packing material

2.4 Mechanical installation

All kind of works on the inverter may be carried out by authorized personnel in accordance with the EMC and safety rules only.

- Switch inverter de-energized and await capacitor discharge time
- Pull off operator
- Remove plastic cover
- Remove fixing bolt
- Fix interface board beginning from the socket connector straightly
- Screw in fixing bolt
- Attach plastic cover

3. Description of the Interface

3.1 Channel 1

3.1.1 Specifications

Slot	X3A
Interface type	Resolver
Field voltage U_{out}	7,2 Vpp $\pm 2\%$; maximum 30 mA; f=9,76 kHz
Input voltage U_{in}	3,6 Vpp $\pm 10\%$
Gear ratio resolver	0,5
Tolerance	$\leq 3\text{Bit}$; i.e. with 4 ms scan time and n=3000 rpm this can lead to speed fluctuations of $\pm 20\text{rpm}$
Particularities	–

3.1.2 Description of the socket X3A

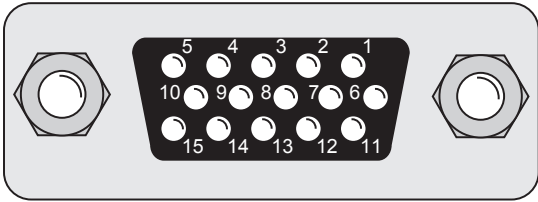
Figure 3.3.1 Socket X3A		
		<p>Attention! Plug connector only when COM-BIVERT and supply voltage are switched off!</p>
PIN	Name	Description
3	SIN_LO	Sine-signal cable low
4	COS_LO	Cosine-signal cable low
5	REF_N	Field voltage output negative
8	SIN_HI	Sine-signal cable high
9	COS_HI	Cosine-signal cable high
10	REF_P	Field voltage output positive
14	GND	Connection for shielding of the signal cables
–	Housing	Shielding of the total cable

3.1.3 Input signals channel 1

3.1.3.1 Signal tracks

A sine-wave voltage is output at terminals REF_HI and REF_LO at the resolver interface. This voltage supplies the field winding in the resolver. This signal is transmitted via a rotary transformer to the rotary part of the resolver.

The pulsating magnetic field induces electrical voltages in the two signal windings which are shifted about 90°. The voltages pulsate with the same frequency and phase position as the field signal. However their amplitudes are depending on the position of the rotor winding. The induced voltage has maximum value if rotor and measuring winding are parallel. No voltage is induced in signal winding in right angle to each other. Both signal voltages are directly transferred to the encoder interface.

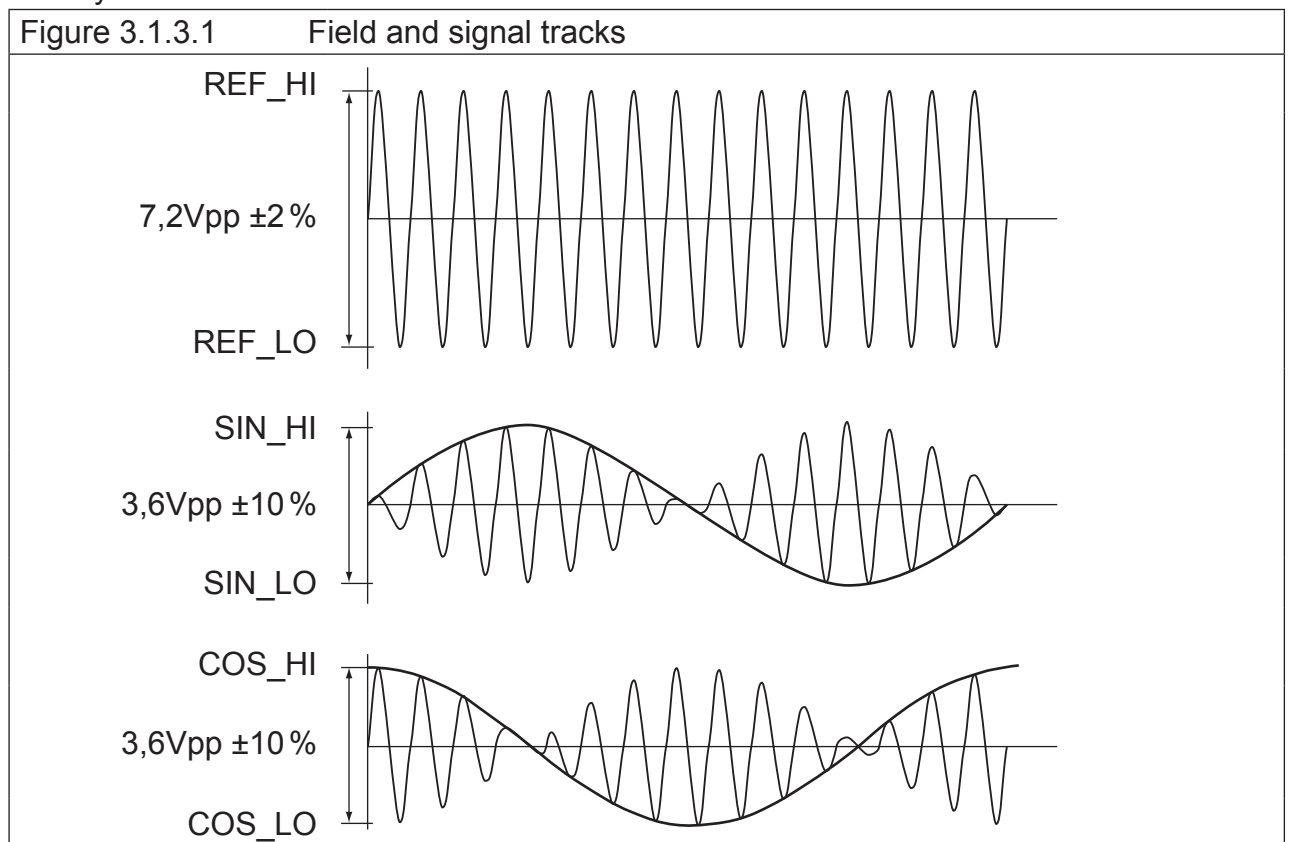

3.1.3.2 Encoder breakage recognition channel 1

Input signals SIN_HI and COS_HI are monitored for the monitoring of the resolver at channel 1. The monitoring for channel 1 will be switched on/off with parameter Ec.42 (in the past Ec.20).

The recognition of encoder breakage triggers an „error! encoder 1" (value 32), if the voltage at signal inputs SIN_HI and COS_HI is outside of the specification.

3.1.4 Connection of the encoder

- Encoder cable double-shielded and twisted in pairs
- Apply external shielding on both sides at the connector housing
- Connect interior shieldings at one side at the interface to GND
- Do not connect exterior and interior shielding

Figure 3.3.4 Connection of the encoder (in accordance with encoder cable 00F50C1-1xxx)

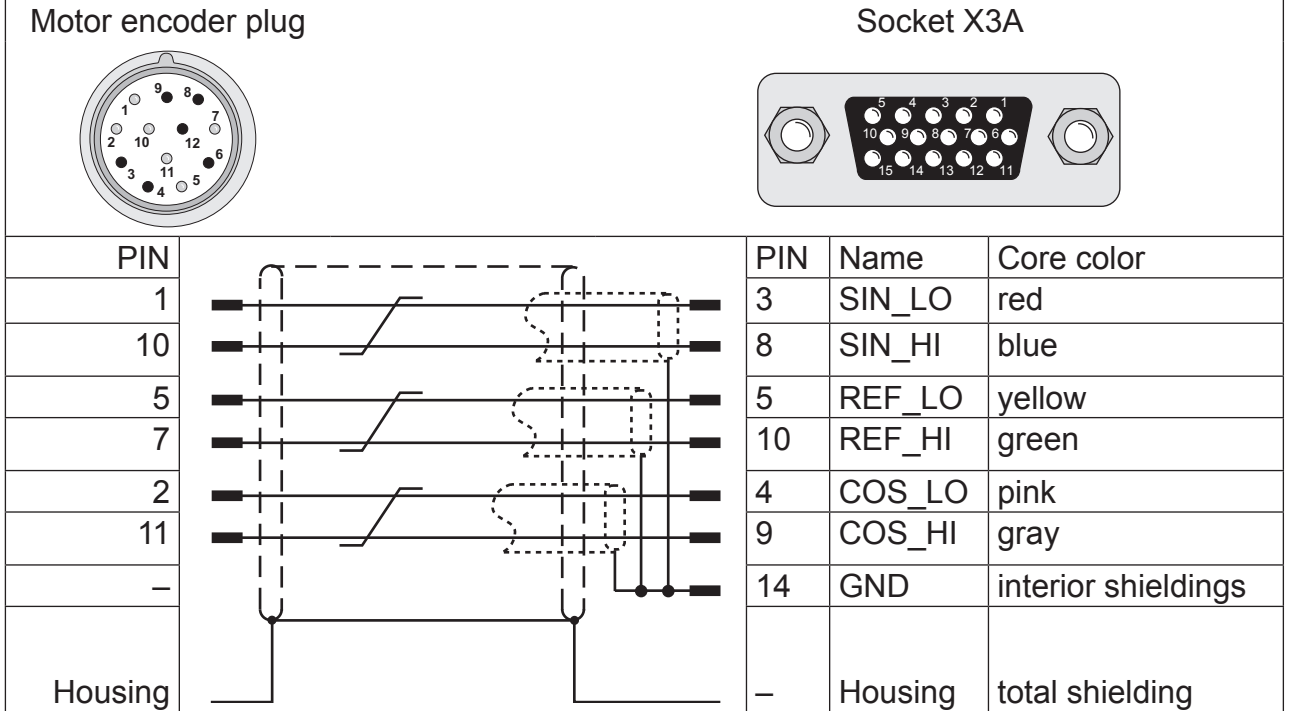

3.1.5 Encoder cable

KEB encoder cables are corresponding to the following specification:

Signal lines	3 x (2 x 0,14 mm ²)
Supply lines	2 x 0,5 mm ²
Particularities	trailing capable, oil-resistant
Temperature range	constant up to 80 °C
Color	green RAL 6018

3.1.6 Encoder line length

The maximum line length of the encoder cable is 50 m. Please contact KEB if longer encoder cables are required.

3.1.7 Tested encoders

The following resolvers have been tested by KEB on it application:

- Tamagawa TS 2620 N21 E11 (default)
- Tamagawa TS 2641 N11 E64
- LTN RE-15-1-A14
- LTN RE-21-1-A05
- Harowe 10BRCX 401 k1C

However, this does not restrict the use of rotary encoder with same specifications of other manufacturers.

3.2 Channel 2

The description of input X3B is depending on the used encoder interface. It is described in a separate manual.

4. Start-up

After the installation or exchange of an encoder interface some adjustments of the inverter/ servo software have to be done before operation:

- Switch on inverter
- Select application mode
- Select parameter Ec.00 and control whether value „19: resolver interface“ is entered. The displayed value has to be confirmed by „ENTER“ in any case.
- Select Ec.42 and adjust the encoder breakage recognition dependent on the case of operation.



The resolver evaluation block generates incremental signals, which can be output via encoder simulation (channel 2 = TTL output). The number of the generated pulses is indicated in Ec.01. Parameter Ec.07 is without function. Exception: control card application

4.1 Special resolver

The use of 2-pole resolvers (pole-pair number 1) is provided as standard. If a resolver with another pole-pair number shall be used, the pole-pair number is to be used as gear factor.

$$\frac{\text{Gear factor denominator}}{\text{Gear factor numerator}} = \text{pole-pair number}$$

If synchronous motors shall be operated in this constellation, it must be guaranteed that the value pole-pair number x gear factor is integer (see example).

Example:

6-pole resolver (3 pole-pairs) at channel 1,
pole-pair number of the synchronous motor = 3

Ec.05 Gear factor channel 1 denomi- nator	3000		
_____	=	_____	= pole-pair number
Ec.04 Gear factor channel 1 numerator	1000		

The operation of encoders which are not directly mounted at the motor or for operation of resolvers with a pole-pair number > 1, parameter Ec.39 must be set to „1: motor encoder“.
The gear factor is 1/3, the pole-pair number of the motor = 3
Gear factor x pole-pair number of the motor = 1
=> Synchronous motor can be operated in this constellation.

5. Error Messages

Error messages and their meaning are described in the inverter documentation.



For safety reasons a power-on-reset must always be executed after error „E.EnC“.



Karl E. Brinkmann GmbH

Försterweg 36-38 • D-32683 Barntrup
fon: +49 5263 401-0 • fax: +49 5263 401-116
net: www.keb.de • mail: info@keb.de

KEB worldwide...

KEB Antriebstechnik Austria GmbH

Ritzstraße 8 • A-4614 Marchtrenk
fon: +43 7243 53586-0 • fax: +43 7243 53586-21
net: www.keb.at • mail: info@keb.at

KEB Antriebstechnik

Herenveld 2 • B-9500 Geraadsbergen
fon: +32 5443 7860 • fax: +32 5443 7898
mail: vb.belgien@keb.de

KEB Power Transmission Technology (Shanghai) Co.,Ltd.

No. 435 QianPu Road, Songjiang East Industrial Zone,
CHN-201611 Shanghai, P.R. China
fon: +86 21 37746688 • fax: +86 21 37746600
net: www.keb.cn • mail: info@keb.cn

KEB Antriebstechnik Austria GmbH

Organizační složka
K. Weise 1675/5 • CZ-370 04 České Budějovice
fon: +420 387 699 111 • fax: +420 387 699 119
net: www.keb.cz • mail: info.keb@seznam.cz

KEB Antriebstechnik GmbH & Co. KG

Wildbacher Str. 5 • D-08289 Schneeberg
fon: +49 3772 67-0 • fax: +49 3772 67-281
mail: info@keb-combidrive.de

KEB España

C/ Mitjer, Nave 8 - Pol. Ind. LA MASIA
E-08798 Sant Cugat Sesgarrigues (Barcelona)
fon: +34 93 897 0268 • fax: +34 93 899 2035
mail: vb.espana@keb.de

Société Française KEB

Z.I. de la Croix St. Nicolas • 14, rue Gustave Eiffel
F-94510 LA QUEUE EN BRIE
fon: +33 1 49620101 • fax: +33 1 45767495
net: www.keb.fr • mail: info@keb.fr

KEB (UK) Ltd.

6 Chieftain Business Park, Morris Close
Park Farm, Wellingborough GB-Northants, NN8 6 XF
fon: +44 1933 402220 • fax: +44 1933 400724
net: www.keb-uk.co.uk • mail: info@keb-uk.co.uk

KEB Italia S.r.l.

Via Newton, 2 • I-20019 Settimo Milanese (Milano)
fon: +39 02 33535311 • fax: +39 02 33500790
net: www.keb.it • mail: kebitalia@keb.it

KEB Japan Ltd.

15-16, 2-Chome, Takanawa Minato-ku
J-Tokyo 108-0074
fon: +81 33 445-8515 • fax: +81 33 445-8215
mail: info@keb.jp

KEB Korea Seoul

Room 1709, 415 Missy 2000
725 Su Seo Dong, Gang Nam Gu
ROK-135-757 Seoul/South Korea
fon: +82 2 6253 6771 • fax: +82 2 6253 6770
mail: vb.korea@keb.de

KEB RUS Ltd.

Krasnokazarmeny proezd 1,
Metrostation „Aviamotornay“
RUS-111050 Moscow / Russia
fon: +007 445 695 3912 • fax: +007 495 645 3913
mail: info@keb.ru

KEB Sverige

Box 265 (Bergavägen 19)
S-43093 Hälsö
fon: +46 31 961520 • fax: +46 31 961124
mail: vb.schweden@keb.de

KEB America, Inc.

5100 Valley Industrial Blvd. South
USA-Shakopee, MN 55379
fon: +1 952 224-1400 • fax: +1 952 224-1499
net: www.kebamerica.com • mail: info@kebamerica.com

More and newest addresses at <http://www.keb.de>

© KEB	
Mat.No.	DRF5ZEM-K001
Rev.	1C
Date	08/2008